

# RI 7100A RF ATE : Fast Testing by Design

Innovations in Hardware and Software emphasize high test speed.

Today's competitive communications marketplace demands innovation to minimize time to market and increase profitability. High throughput ATE enhances Engineering, Marketing and Manufacturing by providing shorter product development cycles, aggressive response to customer requests, and delivery of larger product volumes at a lower cost. Testing speed is the critical factor in high volume, cost-sensitive RF/Microwave ICs & component manufacturing. Every second of time expended on test contributes directly to the end products cost. The need for speed demands a paradigm shift from conventional slow rack RF systems to a new measurement system with ten times the throughput.

## Breaking the Throughput Barrier

The Roos Instruments RI 7100A is a third generation RF/Microwave ATE solution that was conceived primarily to address high volume test requirements. It implements established industry standard measurement techniques in an integrated platform producing the fastest test throughput available today. Complimenting the extremely fast test times, the RI 7100A tester offers higher accuracy and reduced acquisition costs.

An RI 7100A tester has streamlined fast and stable measurement hardware, fast RF sources, fast switching, heavy use of centralized computation, and advanced software. The control software is of leading edge object oriented graphical design . Through use of a sophisticated test plan optimizer and test compiler, programming inefficiencies are easily removed. Utilizing all of these highly integrated assets, an RI 7100A will typically yield a 20 to 30 times improvement in test speed compared with other previously used approaches.

Complimenting it's high measurement speed, the RI7100A's test development software speeds the development of test plans. This advanced environment enables a test engineer to generate test plans very efficiently, in hours or days, instead of months or years. The goal ultimately to capturing market share early which increases profitability dramatically.

## Hardware and Test Speed

The hardware of the RI 7100 is designed to be highly reliable, temperature tolerant and very high speed. By minimizing the drift factors others must constantly calibrate to remove, RI engineers achieve a simplified block diagram that consistently produces the highest possible measurement speed. This innovative system design allows the user flexibility to be incorporated into the easy to use software interface.

RF measurements are made with a single channel vector receiver, utilizing the most advanced computing power to translate those measurements into the desired scattering parameters, power measurement, or noise measurement. The RI vector receiver can make a complex voltage measurement in 10 's of microseconds.

The simplified hardware is under direct control of the software, not hidden behind additional layers of firmware as in off the shelf bench instruments. A fiber optic link with a low overhead protocol replaces the common GPIB bus, enabling fast communication with the sources, switching, and measuring devices. The incredible processing power of the latest PC platform is used for calculating the desired result from the raw measurement data.

## ATE That is Always Ready to Work

Many testing alternatives continue to use slow bench instruments to perform single parameter measurements. These instruments utilize multiple asynchronous processors which actually limit system throughput and MTBF.

Roos Instruments has developed special purpose slave sources and measurement devices that are precisely controlled yielding a deterministic high volume testing environment. This approach utilizes fewer components, simplified switching, and lower costs. The benefit is a RI7100A with much higher MTBF, currently demonstrating approx. 9000 hrs or one failure a year for a system running twenty four hours a day, seven days a week. That's high continued throughput and low cost of ownership!

## Fast RF Sources

The RI 7100A utilizes high accuracy frequency synthesized microwave sources. These sources are extremely clean spectrally with low phase noise and switch frequency in approximately 10-40 milliseconds. Identical sources are utilized as the LO for the receiver and as up to four of the optional measurement stimulus.



## Simple Switching

The simplified design of the measurement hardware also simplifies the switching required. Since all measurements are made by the vector receiver, there is minimal RF path switching needed. Switching of the measurement ports is accomplished by custom 20Ghz bandwidth pin diode based self terminating switches. They have extremely fast switching times, high reliability and provide a 50ohm match to unused ports.

## RF Measurements

A fundamentally mixed down converter design is employed in the receiver for the highest in sensitivity. To support fast pulse and complex modulated waveforms, a wide bandwidth 21 MHz IF is utilized. The final detection bandwidth is user selectable from 5Mhz to 7khz and is sampled by a high speed quadrature I & Q demodulator with a single high accuracy A/D converter. An internal noise source is utilized as a stable power reference standard which the receiver is measured against periodically to ensure it's accuracy and integrity. This innovative combination produces a very sensitive and stable system receiver with wide dynamic range and fast measurement times of 10 us per sample.

The RI 7100A performs S-parameter measurements extremely fast and with high accuracy by utilizing an innovative time reference approach and the single channel receiver. This design eliminates the need for extensive error correction in matching two sets of I & Q demodulators, ( S-parameters are ratios and typically are measured with two receivers that must be matched perfectly in order to make accurate measurements) any small drifts due to time or temperature are common mode rejected.

In high volume testing the ATE must always be available to test parts, as opposed to being forced to use precious test time to calibrate the tester. Temperature effects that change the physical aspects of the test head and reflectometers have been controlled and removed in the design. Less sophisticated designs require constant recalibration. This implementation removes the need to calibrate daily or even weekly and maintains it's calibration a minimum of 6 months!

## Enhanced Accuracy Measurements

Identical hardware paths are used for all the RF measurements, therefore the vector error correction data gathered to produce the corrected S-parameters is applied to error correct all of the other measurements. This capability ensures the correlation from hour to hour, day to day, week to week, and tester to tester on tough measurements like Absolute RF Power, Noise Figure, Gain Compression, and Spectral Purity. Frequency translation devices ( mixers, converters) can now be measured with vector error correction producing accuracy's previously unobtainable.

Noise Figure is measured utilizing the widely accepted Y-factor power technique. Since power measurements are vector error corrected, the noise figure measurement is enhanced. This process is extremely efficient and results in the fastest measurement time ( 70 milliseconds ) on the market!

The RI 7100A utilizes a unique technique for measuring gain compression that results in test times an order of magnitude faster than otherwise available. Utilizing a sophisticated curve fitting algorithm, the compression point is derived in less than 1 millisecond.

## PC vs. Internal Instrument Processor

Bench instruments typically use low powered processors for economy. The targeted use is by engineers running the instrument via the front panel. In this use, several hundred milliseconds of calculation and error correction may be acceptable.

The RI 7100 uses the latest high powered PC's with perhaps 100 times the power of the processor in a bench instrument. An RI7100 can make calculations and error corrections hundreds of times faster than a bench instrument. If desired, this calculation can be moved out of the critical test path to achieve even faster test times.

## Use of Wafer Probers and Device Handlers

The RI 7100 is designed to cleanly interface with wafer probes and device handlers and can use them to the best of their capabilities. (Highly developed interfaces to over 30 wafer probes and handlers are available.) The capabilities include cassette to cassette systems, tape and reel, tube and tray feed handlers.

## Software and Test Speed

Software is a critical component of the testing process. The RI 7100 uses a object-oriented system that provides unique advantages in testing speed and real time development of the test plan.

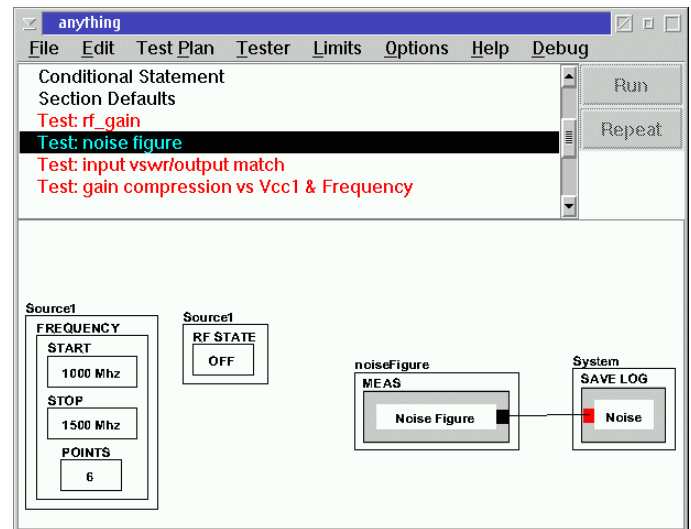

## Test Optimizer

The test optimizer operates at the time the test plan is designed. It breaks the test plan into hundreds or thousands of basic elements and then rearranges the elements to minimize the actual test time.

No competing software even considers optimizing the test sequence to minimize test time. In current compilers, optimization is a necessity offering significant improvement in execution time. The lack of this feature in other systems, while understandable due to the complexity of the problem, forces the test engineer to structure his program around the equipment for speed as well as function, adding significantly to the cost and time required to develop the software.

Systems using low level hardware and C/C++ controlling programs have the potential to achieve fast test times. However the person who is programming the test must be very facile with low level tools such as C, C++, or possibly assembly language. The test processes must be specified in minute detail, with detailed knowledge of the testing hardware. This process is very time consuming and tedious. Generally, the first goal is that the test program run correctly at all, not that it be optimized for testing speed. Generating a correct test program in this approach may take months or years

## Test Compiler

Most existing software packages are interpreters which means that they must compile and execute each test statement every time it is called. This differs from current state-of-the-art software where the compilation is done once and the executes many times. Since the compile is the slow process, these packages can be 10 times slower than compiled software.

## Relational Database Support

RF and microwave testing typically generates a large amount of data. Production and development organizations usually want to use this data to refine the development and characterization process. For the test data to be available and usable, it must be stored in a readily available format. The most usable and versatile storage is an industry standard relational database. The interface to relational storage is included in the RI 7100 tester.

However storing relational data as generated may limit testing speed. Most relational databases work at a rate of 10 to 50 transactions per second. The RI 7100 maintains a cache for data on the PC, with test data stored to the database as capacity allows.

## Custom Test Services

Roos Instruments offers complete custom turn key test service with the RI7100A for the highest level of customer satisfaction. The professional RI design staff is available to perform the following:

RF Test Fixture Design and Fabrication

Expert RF DUT Board Design, Layout, and Fabrication

Test Plan Development

RF Test Correlation Assistance

Handler, Prober, or Robot Mechanical Interfacing

## Summary

The RI 7100A is designed from the ground up for high test throughput. The fast RF switching times, high speed measurements, and optimized software make fastest test times possible. Test rates of 40,000 tests per second are routine for many common tests.

Complimenting it's extremely fast test times, the RI 7100A has a lower capital acquisition cost, and higher test accuracy. The ATE software enables fast development, debugging, and maintenance of test programs which combine to provide the lowest life-cycle-cost of any RF test approach on the market. This tester is a must for a serious RF, IF, and MMIC product to achieve a winning position in today's communications marketplace.